

Kit 1595

VOLVO S80, 4-dr Sedan, 06- / *07-

*North America

480R
754

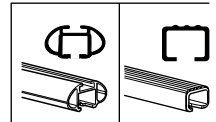
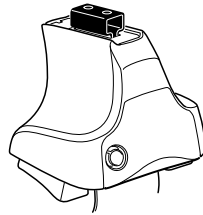

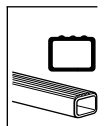
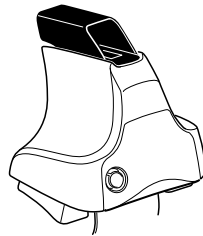

480



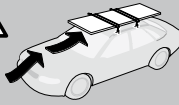

 $xx \text{ kg} + 7 \text{ kg} =$
 $xx \text{ lbs} + 15,4 \text{ lbs} =$



Max. 75kg
Max. 165 lbs







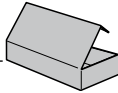

80 km/h 130 km/h
 50 Mph 80 Mph
 40 km/h 25 Mph
km/h / Mph

THULE

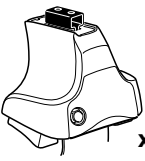

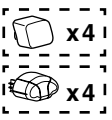

Kit XXXX
 instructions

x1 **x4** **x4**





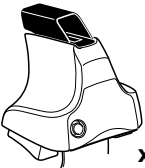



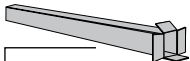

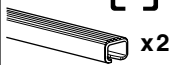

480R/754



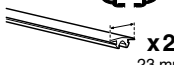

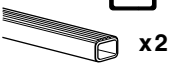
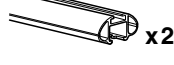
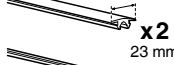
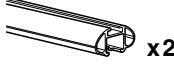

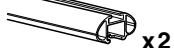
x1 **x4** **x4**

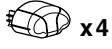
480



  x2	  x2 23 mm	  x1 17 mm	  x2 23 mm	  x2
	 x2	 x2 23 mm	 x2	
	 x4	 x2		
	 x4	 x4		

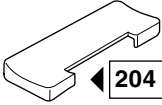
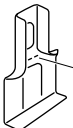
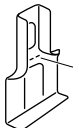
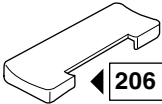
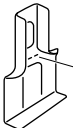
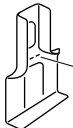

 204 x2	 815 x1	 817 x1
 206 x2	 816 x1	 818 x1



x1

Kit

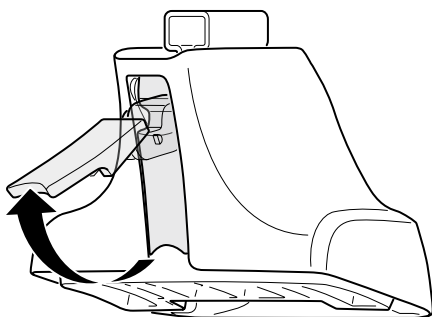
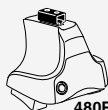
1

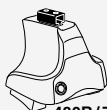

2



+

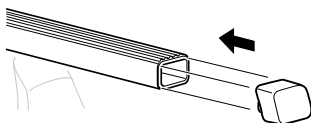
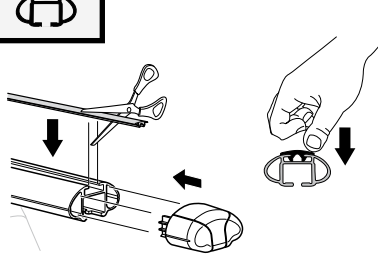
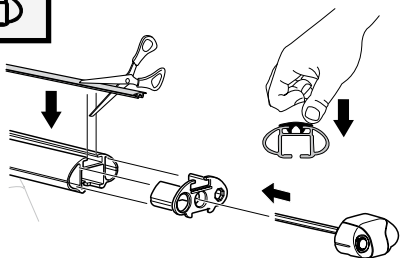
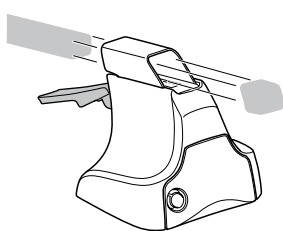
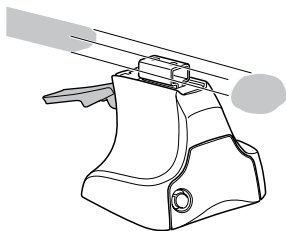

3

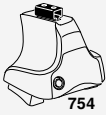

754

1

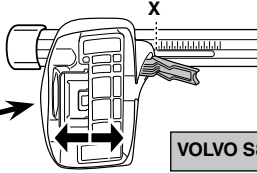
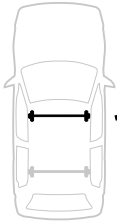

2

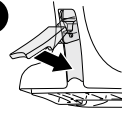

VOLVO S80, 4-dr Sedan, 06- / *07-

X
44

1

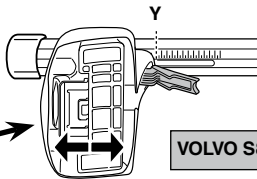
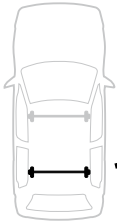

2

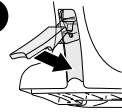

VOLVO S80, 4-dr Sedan, 06- / *07-

Y
37,5

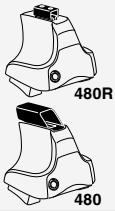

480R

480

1

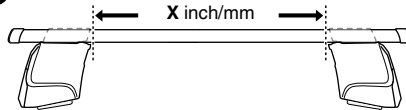

2

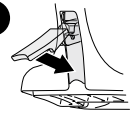

X inch	X mm
43"	1091 mm

1

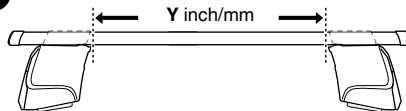

2

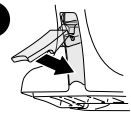

Y inch	Y mm
40 3/8"	1026 mm

4



480R/754



480

VOLVO S80, 4-dr Sedan, 06- / *07-

204

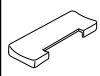

815

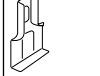

206

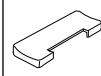

816

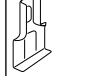

206

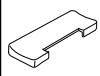

817



204

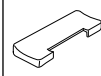

818

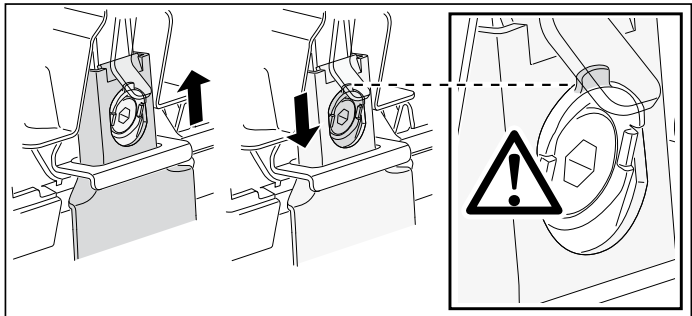
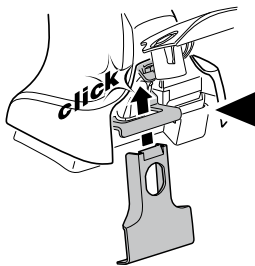
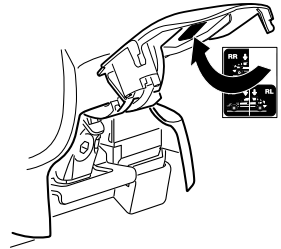
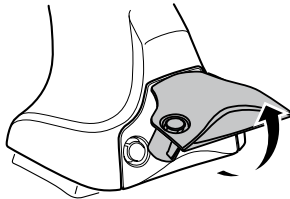
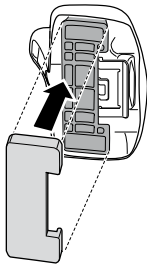
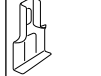

5



	X mm	Y mm	X inch	Y inch
VOLVO S80, 4-dr Sedan, 06- / *07-	240 mm	640 mm	9 1/2"	25 1/4"

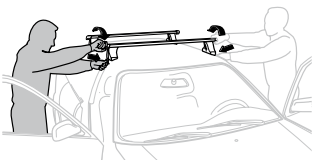
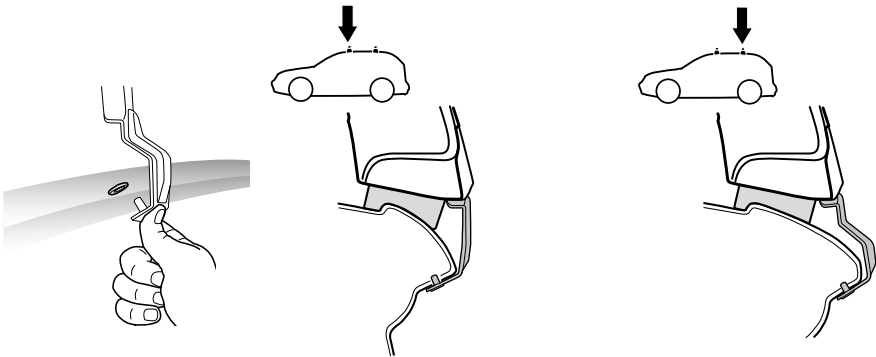
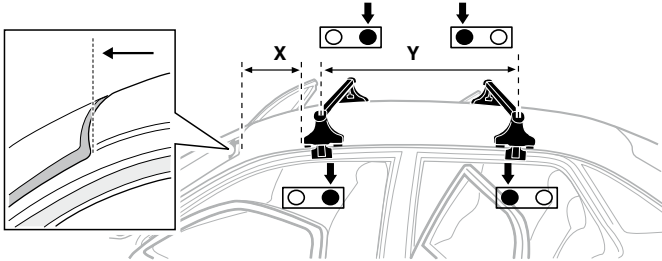

- | | | | |
|--------------|---|------------|---|
| GB/US | Tighten alternately | CZ | Pokřetla bagażnika dokręcaj dokręcaj naprzemiennie. |
| D | Die Schrauben abwechselnd anziehen | SK | Dofahujte striedavo |
| F | Serrer alternativement chaque côté | SLO | Privijajte izmenično. |
| NL | Afwisselend aan de linker- en de rechterkant aandraaien | HR | Naizmjenično zategniti |
| I | Alternare il serraggio delle viti | HU | Egymástól függetlenül szorítandó |
| E | Apretar alternativamente | GR | Σφιγγετε εναλλάξ |
| PT | Aperte alternadamente | TR | Dönüşümlü sıkın |
| S | Dra åt växelvis | 中文 | 交替拧紧 |
| FIN | Kierrä vuorotellen | 한국어 | 번갈아 가며 조이십시오. |
| EST | Pinguldage vaheldumisi | 日本語 | 交互に締め付けてください。 |
| LAT | Pievelciēt pamīšus | ไทย | ขันในแบบสลับ |
| LIT | Užsukinėkite pakaitomis | | |
| PL | Śruby dokręcaj naprzemiennie | | |
| RU | Затягивайте попеременно | | |

6

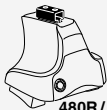

480R/754



480

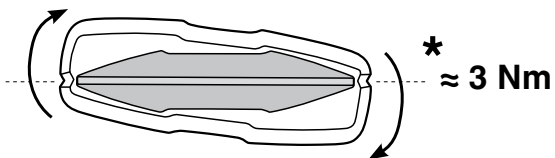
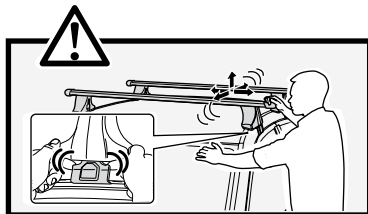
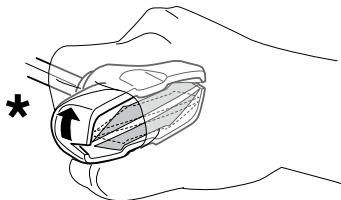
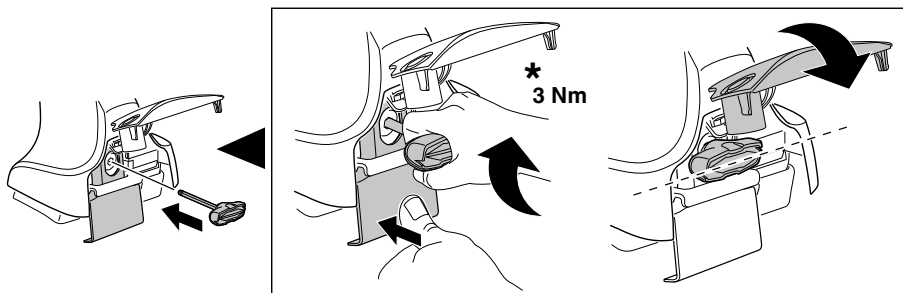

7

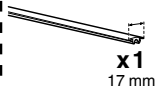

x1
17 mm

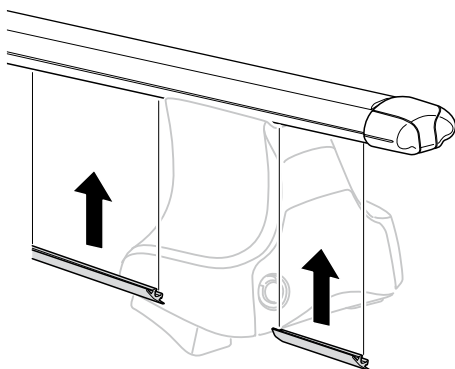

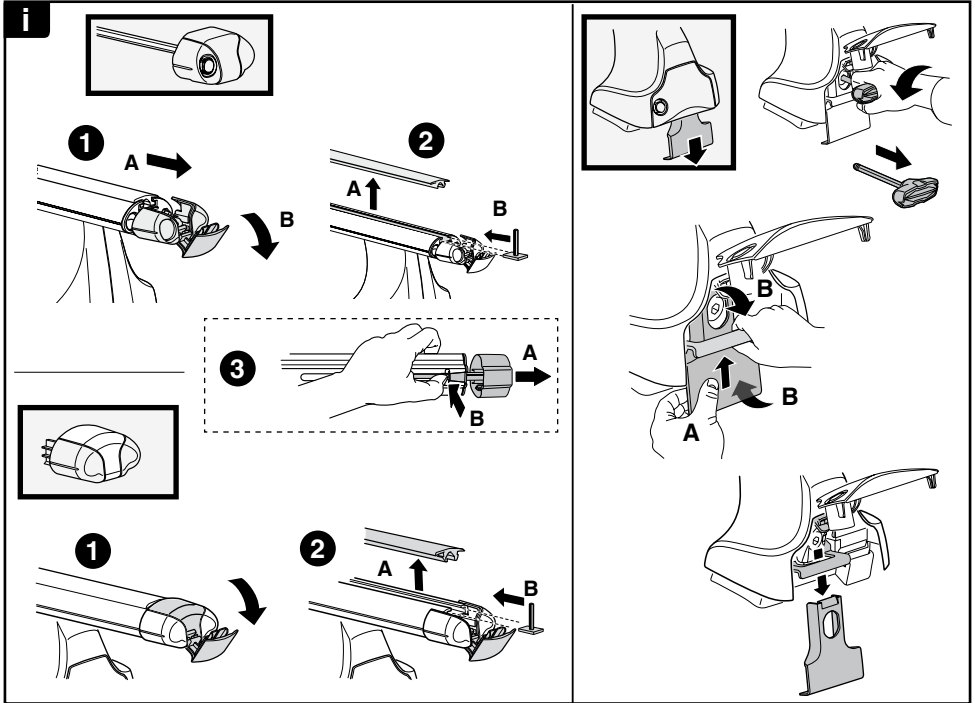

THULE
SWEDEN
**ONE
KEY
SYSTEM**

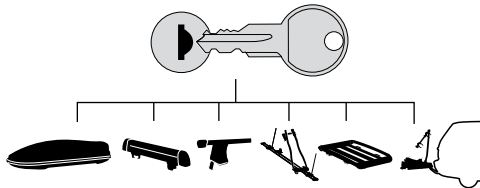

544 (x4)

596 (x6)

588 (x8)

NA **510** (x10)

EUR **452** (x12)
ASIA

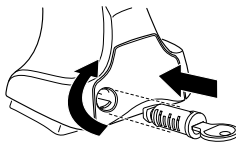

WW ▶ Thule Sweden AB, Box 69, 330 33 Hillerstorp, SWEDEN
NA ▶ Thule Inc., 42 Silvermine Road, Seymour, Connecticut 06483, USA

info@thule.com
customer.service@thule.com

www.thule.com